

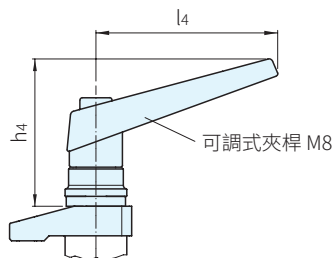

材質	處理
鋼	表面硬化、染黑

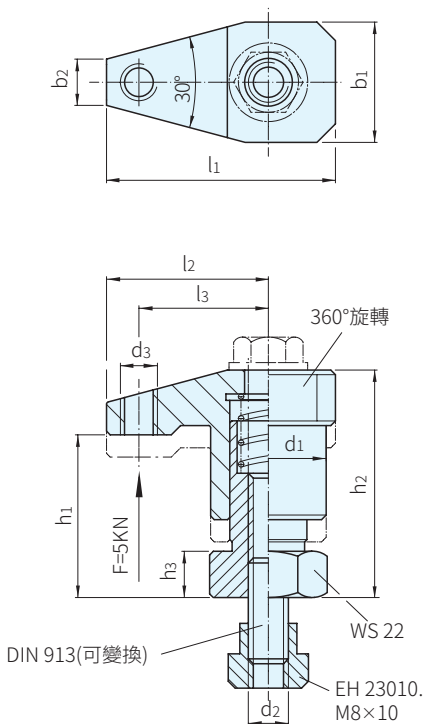

23310.0024

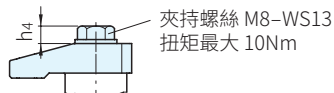

23310.0025

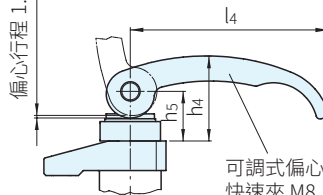

23310.0026

品號	d ₁	b ₁	b ₂	d ₂	d ₃	h ₁ MIN.	h ₁ MAX.	h ₂ MIN.	h ₂ MAX.	h ₃	h ₄	h ₅	l ₁	l ₂	l ₃	l ₄	行程 mm	質量 g	庫存
23310.0024											60.0	-					74	363	△
23310.0025	25	26	10	M8	M8	30	35	44	49	10	6.9	-	49.5	35	28		5	227	△
23310.0026											35.0	20.5					82	340	△

WA. 注意

・DIN 508可依需求換成M8×12，M8×14

訂貨： 交期： 天

23310.0024

EX. 使用例

